

EN 1994 - Eurocode 4: Design of composite steel and concrete structures

Composite slabs

Stephen Hicks BEng(Hons), PhD(Cantab.)
Senior Manager Building Engineering
The Steel Construction Institute
Silwood Park
Ascot, Berkshire, SL5 7QN
United Kingdom
Telephone: +44 (0)1344 636540, Fax: +44 (0)1344 636570
E-mail: s.hicks@steel-sci.com

INTRODUCTION

Composite construction has proved popular over the last twenty years, and has largely accounted for the dominance of steel frames in multi-storey buildings within the UK. The main benefits in using composite beams are that:

- Savings in steel weight of between 30 to 50% can be achieved compared to non-composite beams.
- The increased stiffness of composite beams can result in them being shallower than non-composite beams for the same span; this can lead to lower storey heights and a reduction to cladding costs (which is significant, as cladding can represent up to 20% of the total building cost[1]), or allowing more room for mechanical services.

The cold formed profiled steel sheeting is an integral part of the structural system as it performs the following roles:

- It acts as a safe working platform and protects the workers below.
- It supports the loads during construction and may eliminate the need for temporary propping.
- It acts as permanent formwork for the concrete slab.

- Through mechanical or frictional interlock (and/or the provision of end anchorage), composite action can develop with the concrete such that the sheet provides all, or part, of the main tension reinforcement to the slab.
- Through the provision of through-deck welded stud shear connectors, the composite slab may be used to provide restraint to the steel beams.

TYPES OF PROFILED STEEL SHEET

There are many types of profiled steel sheet used in composite slabs; these types vary in form depending on the target span for the product and the resulting resistance and stiffness requirements in the construction and composite stage. However, profiled steel sheeting used in composite construction may be divided into two broad categories: open trough profiles (see Fig 1) and re-entrant profiles (see Fig 2).

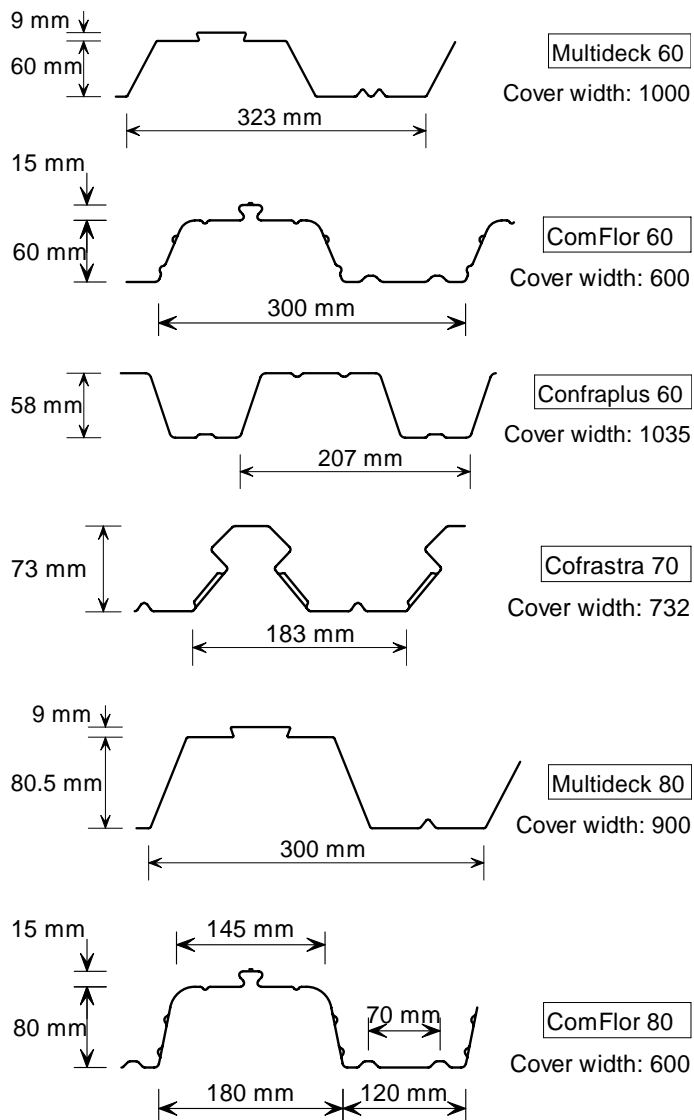

Fig 1. Examples of open trough profiled steel sheets used for composite slabs

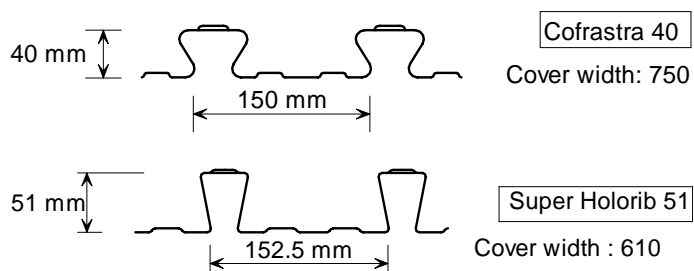

Fig 2. Examples of re-entrant profiled steel sheets used for composite slabs

To resist the loads and provide sufficient stiffness at the construction stage, the cross-section of the sheet may be designed using the equations given in EN 1993-1-3; in spite of this, it is more common for the manufacturer to publish design properties that have been evaluated from the test procedures given in Annex A of this Eurocode. The benefit of using design properties evaluated from tests is that greater spanning capabilities may be achieved (typically, spans of between 10 to 15% in excess of those predicted by the design equations given in EN 1993-1-3 may be possible).

The rules in EN 1994-1-1 are only appropriate for profiled steel sheeting thicknesses above a certain value; although the minimum nominal thickness may be given in the National Annex, the recommended value is $t \geq 0,70$ mm. Typically, profiled steel sheeting is galvanized for durability purposes. In these situations care should be taken on the thickness that is used in design owing to the fact that the sheet thickness that is often quoted by manufacturers is the overall thickness, including the galvanized coating, rather than the core or 'bare metal' thickness which should be used in structural calculations. For example, for a coating of 275 g/m^3 , the core thickness is approximately 0,04 mm smaller than the overall thickness of the sheet.

The application of EN 1994-1-1 is limited to sheets with narrowly spaced webs, which are defined by the ratio of the width of the sheet rib to the rib spacing b_r / b_s ; although the upper limit may be given in the National Annex, the recommended value is $b_r / b_s \leq 0,6$.

TYPES OF SHEAR CONNECTION

To enable composite action to be assumed between the profiled steel sheet and the concrete, the longitudinal shear force should be transferred by the sheet by the following forms of connection:

- a) Mechanical interlock through the provision of indentations or embossments rolled into the profile (see Fig 3(a)).
- b) Frictional interlock for re-entrant profiles (see Fig 3(b)).

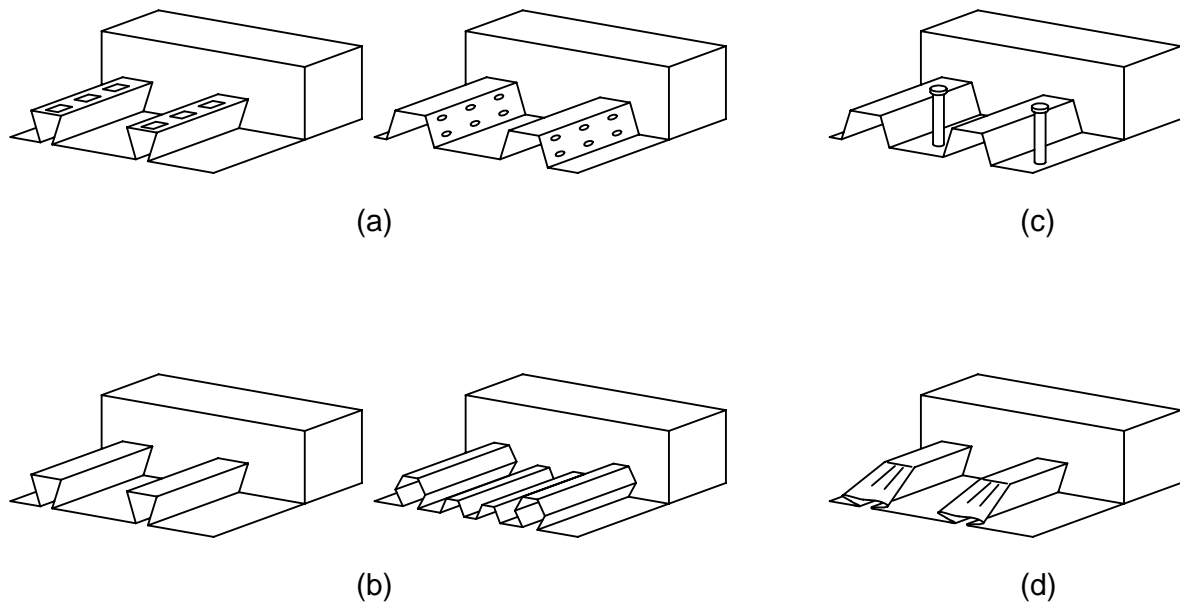

Fig 3. Typical forms of shear connection in composite slabs

According to EN 1994-1-1, it is not permitted to rely on pure bond between the steel sheet and the concrete; the differentiation between pure bond and frictional interlock is that frictional interlock is what remains after a composite slab is subjected to 5000 cycles of load in a standard test. For cases when the mechanical or frictional interlock is not sufficient, the shear connection may be augmented by providing anchorage at the end of the sheet from:

- c) Through-deck welded stud connectors, or any other local connection between the steel sheet and the concrete (see Fig 3(c)).
- d) Deformation of the ends of the ribs at the end of the sheeting (see Fig 3(d)).

The most common way of providing anchorage to a sheet is from through-deck welded stud connectors; however, it should be noted that the safe span tables published by the manufacturers often do not include this beneficial effect, owing to the fact that the sheeting can sometimes be bearing on masonry walls.

DETAILING PROVISIONS

Based on the satisfactory performance of floors that had previously been constructed in a wide range of countries, EN 1994-1-1 specifies the following minimum slab thicknesses that should be used in design:

- Where the slab acts compositely with a beam, or is used as a diaphragm:
 - the overall depth of the slab $h \geq 90$ mm; and
 - the thickness of concrete above the main flat surface of the top of the ribs of the sheeting $h_c \geq 50$ mm.

- Where the slab does not act compositely with a beam, or has no other stabilising function:
 - the overall depth of the slab $h \geq 80$ mm; and
 - the thickness of concrete above the main flat surface of the top of the ribs of the sheeting $h_c \geq 40$ mm.

EN 1994-1-1 also specifies that the minimum amount of reinforcement in both directions should not be less than $80\text{mm}^2/\text{m}$ (which is based on the smallest value of h_c and the minimum percentage of crack-control reinforcement for unpropped construction). It is also specified that the spacing of the reinforcement bars should not exceed $2h$ or 350 mm, whichever is the lesser.

In addition to the above, the largest nominal aggregate size d_g should satisfy the following:

$$d_g \leq \begin{cases} 0,4h_c \\ b_0 / 3 \\ 31,5 \text{ mm} \end{cases} \quad (1)$$

The bearing length is the longitudinal length of sheeting or slab in direct contact with the support. In each case this length should be sufficient to satisfy the relevant criterion. For sheeting, it should be sufficient to avoid excessive rib deformations, or web failure, near the supports during construction. For the slab, it should be sufficient to achieve the required resistance of the composite slab. The recommended bearing lengths and support details differ depending upon the support material (steel, concrete, etc.), and they are different for interior and exterior supports. According to EN 1994-1-1, the bearing lengths l_{bc} and l_{bs} should not be less than the following (see Fig 4):

- for composite slabs bearing on steel or concrete: $l_{bc} = 75$ mm and $l_{bs} = 50$ mm;
- for composite slabs bearing on other materials: $l_{bc} = 100$ mm and $l_{bs} = 70$ mm.

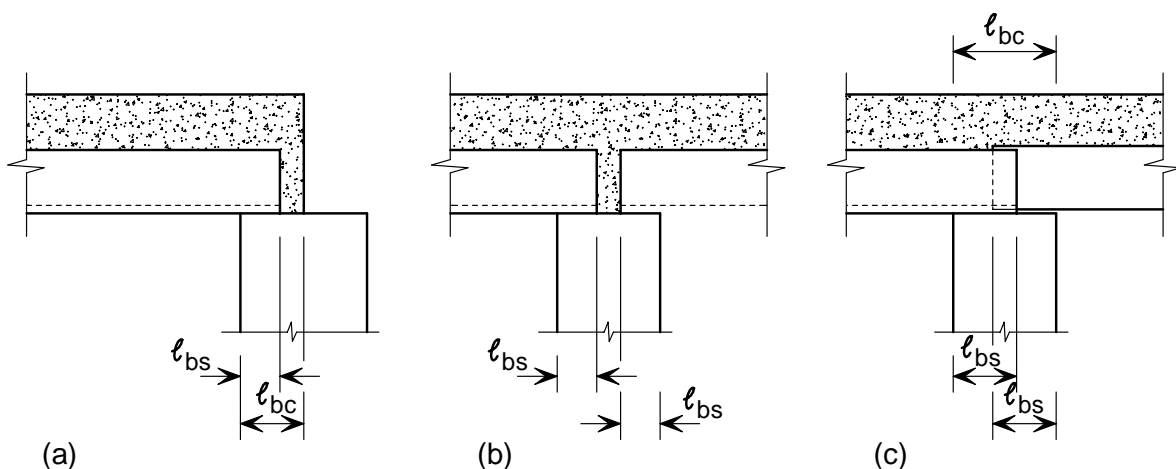

Fig 4. Minimum bearing lengths

The detail in Fig 4(c) may not be practical, owing to the fact that through-deck welding of studs through two thicknesses of sheet is not recommended.

ACTIONS AND ACTION EFFECTS

PROFILED STEEL SHEETING

For both speed and simplicity of construction, unpropped construction is normally used for profiled steel sheeting (i.e. without temporary propping). For this type of construction the sheet thicknesses are normally between 0,86 and 1,16 mm and are provided in continuous two-span lengths to benefit from continuity over the central support. In this situation the spanning capability of the sheeting is normally dictated by resistance or deflection criteria at the construction condition.

The loading that should be considered in the design of the decking is given in EN 1991-1-6. For normal concrete, EN 1991-1-1 recommends that the density should be taken to be 24 kN/m^3 , increased by 1.0 kN/m^3 for normal reinforcement and increased by a further 1.0 kN/m^3 when the concrete is unhardened. As a consequence of this, the self weight load that should be considered in the construction condition corresponds to the design thickness of the slab with a normal concrete density of 26 kN/m^3 . An additional load from the increased depth of concrete arising from the deflection of the sheeting (known as 'ponding') should also be included. According to EN 1994-1-1, if the central deflection of the sheeting δ is greater than $1/10$ of the slab thickness, ponding should be allowed for. In this situation the nominal thickness of the concrete over the complete span may be assumed to be increased by $0,7\delta$.

As well as the self weight of the fresh concrete, EN 1991-1-6 specifies an imposed load consisting of a moving $3 \text{ m} \times 3 \text{ m}$ working area (or the length of the span if less), with an intensity of 10% of the self-weight of the concrete but $\leq 1,5 \text{ kN/m}^2$ and $\geq 0,75 \text{ kN/m}^2$; this load represents the concreting operation and heaping of concrete locally. Outside the working area, an imposed load of $0,75 \text{ kN/m}^2$ should be applied to the profiled steel sheeting.

ANALYSIS FOR INTERNAL FORCES AND MOMENTS

PROFILED STEEL SHEETING

In the analysis of unpropped profiled steel sheeting, it is possible to permit the moment over the internal supports to be redistributed into the span at the ultimate limit state. For profiled steel sheeting that was common to the UK in the 1980's, the amount of plastic redistribution that was assumed was between 5 and 10%[2]; however, greater values of redistribution are capable for some modern steel sheets and, in these situations, the

exact amount that may be assumed in design has been evaluated from tests according to EN 1993-1-1, Annex A.

The use of temporary props permits much longer spans and/or thinner sheets to be used. In this situation the spanning capability of the system is often dictated by the longitudinal shear resistance of the shear connection to the composite slab. However, unlike unpropped construction, EN 1994-1-1 does not permit plastic redistribution at the ultimate limit state when temporary supports are used.

COMPOSITE SLAB

According to EN 1994-1-1, the following methods of analysis may be used for composite slabs at the ultimate limit state:

- a) Linear-elastic analysis with, or without redistribution.
- b) Rigid plastic global analysis provided that it is shown that sections where plastic rotations are required have sufficient rotation capacity.
- c) Elastic-plastic analysis, taking into account the non-linear material properties.

As the sheeting is provided in two-span lengths, together with the fact that the concrete is cast on top of the sheets without joints, the composite slab is normally continuous (details on numerical and experimental results on continuous slabs are given in reference[3]). However, although the finished slab is continuous, it can sometimes be beneficial for designers to assume that it is simply-supported in normal conditions and use linear-elastic analysis. This design approach is often used in the UK, and the continuity that exists over the supports from the provision of nominal anti-crack reinforcement bars, together with any supplementary reinforcement, is only taken into account of in fire conditions[4].

VERIFICATION OF PROFILED STEEL SHEETING AS SHUTTERING

The design properties of the profiled steel sheeting should be evaluated using the design equations or tests according to EN 1993-1-3. For the ultimate limit state, the resistance of the sheet to sagging and hogging bending, together with the effects of combined bending and web crushing, are normally critical. For the serviceability limit state, although the limiting value of the deflection $\delta_{s,max}$ of steel sheeting under its own weight plus the weight of wet concrete may be given in the National Annex, the recommended value is $L/180$ (where L is the effective span between supports).

VERIFICATION OF COMPOSITE SLABS FOR ULTIMATE LIMIT STATES

FLEXURE

The bending resistance of composite slabs may be calculated from EN1994-1-1 using the 'partial connection' or the ' $m-k$ ' method. Both methods rely on tests on composite slabs to evaluate the shear connection, or 'shear bond' value, for the variables under investigation. The tests consist of two groups of composite slabs subjected to two concentrated loads applied at a distance L_s from the supports. For each variable investigated, the groups of composite slab specimens should include the following:

- Test specimens with the shear span L_s as long as possible, whilst still providing failure in longitudinal shear.
- Test specimens with the shear span L_s as short as possible (but not less than $3 \times$ overall slab thickness), whilst still providing failure in longitudinal shear.

For the partial connection method, a minimum of four tests should be undertaken comprising three long specimens and one short specimen (to classify whether the behaviour is ductile or brittle). Conversely, for the $m-k$ method, a minimum of six tests should be undertaken with three long specimens and three short specimens.

No guidance is given in EN 1994-1-1 on the minimum number of variables that should be investigated by tests; however, there is some evidence that the shear bond value is affected by slab thickness and it has been recommended[5] that, for a constant shear span, the thinnest and thickest slab depths should be investigated.

The test loading procedure is intended to represent that which would occur on the floor over a period of time. The initial test consists of subjecting the composite slab test to 5000 cycles of load to eliminate pure bond between the sheet and the concrete so that only the mechanical or frictional interlock remains; this is followed by a subsequent test, where the slab is progressively subjected to load until failure occurs. A typical example of a composite slab test under load is shown in Fig 5.

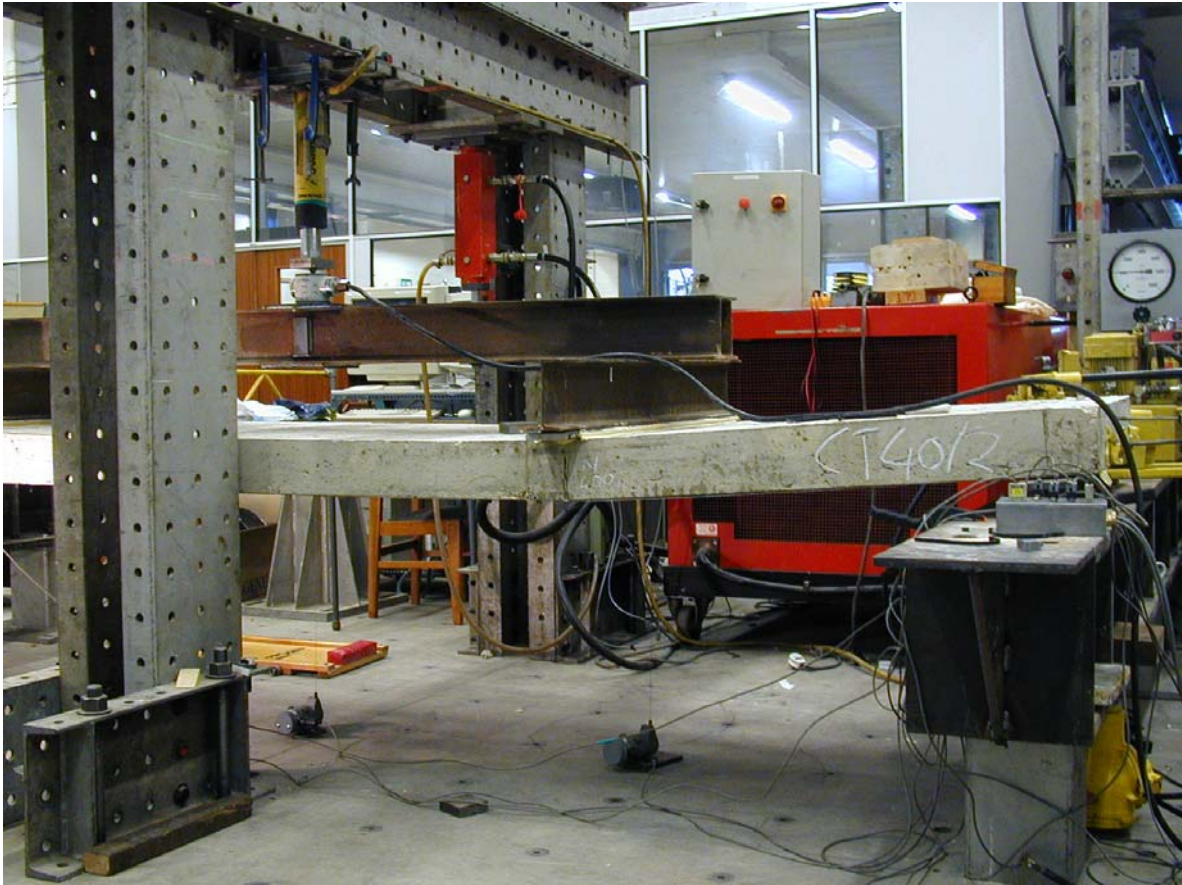

Fig 5. Typical composite floor slab test

The bending resistance design methodology for the composite slab is highly dependant on the behaviour of test specimens. For cases when the longitudinal shear behaviour may be considered as ductile, both the partial connection and $m-k$ method may be used. However, if the behaviour is brittle, only the $m-k$ method is permitted and a 20% penalty is applied to the test results. According to EN 1994-1-1, the longitudinal shear behaviour may be considered ductile if the failure load exceeds the load causing a recorded end slip of 0,1 mm by more than 10%.

Partial connection method without end anchorage

The rules in EN 1994-1-1 are primarily based on the research by Stark and Brekelmans[3]. As implied by the name, the partial connection method is based on establishing the amount of shear connection between the concrete and the sheet for a given bending resistance. The bending resistance of the composite slab is based on simple plastic theory using rectangular stress blocks for the concrete and profiled steel sheeting (and, when included, end anchorage and reinforcement within the ribs). It is also assumed that, before the maximum moment is reached, there is a complete redistribution of longitudinal shear stress at the interface between the sheet and the concrete such that a mean value for the longitudinal shear strength τ_u can be calculated;

because of this assumption, the partial connection method may only be used when the longitudinal shear behaviour in tests has been shown to be ductile.

The degree of shear connection η is defined by:

$$\eta = N_c / N_{c,f} \quad (2)$$

where N_c is the compression force in the concrete and $N_{c,f}$ is the compression force in the concrete for full shear connection.

The variation in bending resistance with degree of shear connection is shown graphically in Fig 6. For cases when $\eta = 0$ composite action between the steel sheet and the concrete does not exist and it is assumed that the bending resistance is provided by the profiled steel sheet alone. For cases when $\eta = 1$, full shear connection exists such that the full tensile resistance of the sheet is developed, or the full compressive resistance of concrete above the ribs of the sheet is mobilised. For intermediate cases such that $0 < \eta < 1$, partial shear connection exists; this case is typical for open trough profiled steel sheets of the type shown in Fig 1.

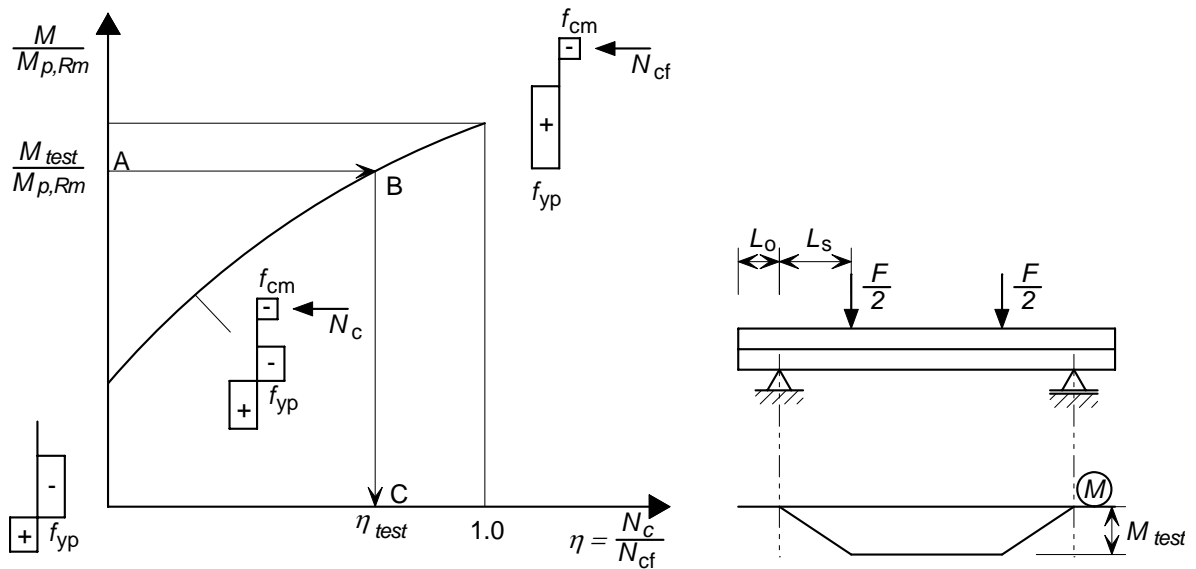

Fig 6. Determination of the degree of shear connection for the partial shear connection method

For a given bending resistance, the degree of shear connection provided in the test η_{test} can be evaluated from the points ABC in Fig 6. By neglecting the effect of the support reaction, the longitudinal shear strength τ_u can then be obtained from:

$$\tau_u = \frac{\eta_{test} N_{c,f}}{b(L_s + L_o)} \quad (3)$$

where $N_{c,f}$ is the compressive normal force in the concrete flange with full shear connection, b is the width of slab, L_s is the shear span and L_o is the length of the overhang (see Fig 6).

If the additional longitudinal shear resistance caused by the support reaction is taken into account, Equation (3) becomes:

$$\tau_u = \frac{\eta_{\text{test}} N_{\text{cf}} - \mu V_t}{b(L_s + L_o)} \quad (4)$$

where μ is the friction coefficient (taken as 0,5) and V_t is the support reaction under the test load.

The characteristic shear strength $\tau_{u,Rk}$ should be calculated from the test values as the 5% fractile using EN1990, Annex D; this is divided by the partial safety factor γ_{VS} to obtain a design value $\tau_{u,Rd}$. Although the value of γ_{VS} may be given in the National Annex, the recommended value in EN 1994-1-1 is 1,25. In preparations for the UK National Annex by the present author, it is interesting to note that, using EN1990 to calculate the appropriate value for γ_{VS} directly, the variability in the results from tests on UK sheets would suggest that the recommended value in EN 1994-1-1 should be increased by 20% when the support reaction is taken into account (Equation (4)).

In calculating the sagging bending resistance of the composite slab using simple plastic theory, there are three possible cases that may be encountered in practical design:

Neutral axis above the sheeting and full shear connection ($\eta = 1$)

For this case, the distribution of stresses for sagging bending is given in Fig 7.

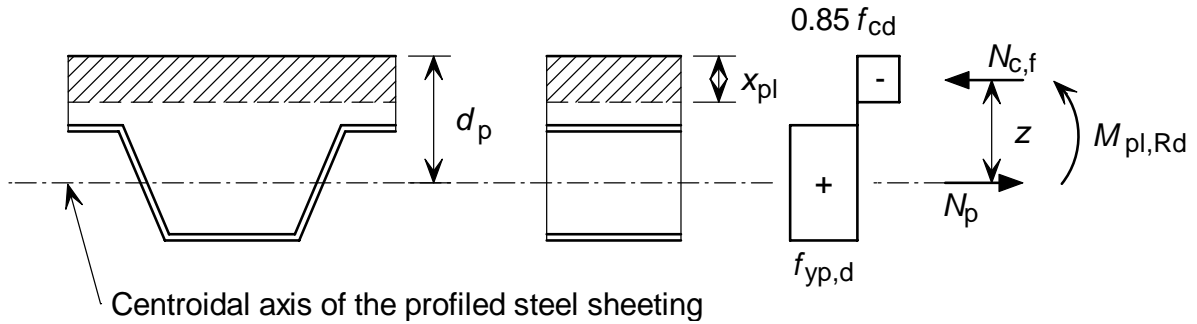

Fig 7. Stress distribution for sagging bending when the neutral axis is above the steel sheeting

For full shear connection, the design compressive normal force in the concrete flange $N_{c,f}$ is equal to:

$$N_{c,f} = N_p = A_{pe} f_{yp,d} \quad (5)$$

where A_{pe} is the effective cross-sectional area of the profiled steel sheeting and $f_{yp,d}$ is the design value of the yield strength of the profiled steel sheeting.

The depth of the concrete in compression is then:

$$x_{pl} = N_{c,f} / (0,85 f_{cd} b) \leq h_c \quad (6)$$

where f_{cd} is the design value of the cylinder compressive strength of concrete and h_c is the thickness of concrete above the main flat surface of the top of the ribs of the sheeting.

Therefore, the design moment resistance of the composite slab in sagging bending is:

$$M_{Rd} = N_{c,f} (d_p - 0,5 x_{pl}) \quad (7)$$

where d_p is the distance between the centroidal axis of the profiled steel sheeting and the extreme fibre of the composite slab in compression ($d_p = h - e$), h is the overall depth of the slab and e is the distance from the centroidal axis of profiled steel sheeting to the extreme fibre of the composite slab in tension.

Neutral axis within the sheeting and full shear connection ($\eta = 1$)

For this case, the distribution of stresses for sagging bending is given in Fig 8.

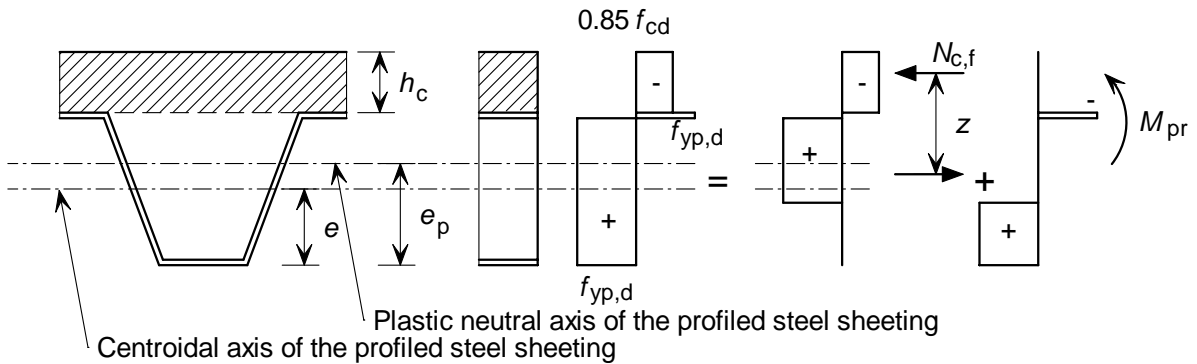

Fig 8. Stress distribution for sagging bending when the neutral axis is above the steel sheeting

For full shear connection, the design compressive normal force in the concrete flange $N_{c,f}$ is less than that given by Equation (5) and, neglecting the compression within the ribs, is equal to:

$$N_{c,f} = 0,85 f_{cd} b h_c \quad (8)$$

where A_{pe} is the effective cross-sectional area of the profiled steel sheeting and $f_{yp,d}$ is the design value of the yield strength of the profiled steel sheeting.

Owing to the fact that $A_{pe}f_{yp,d} < 0,85 f_{cd} b h_c$, there is some available resistance from the profiled steel sheeting in bending. The reduced plastic moment resistance of the sheeting due to the coexistent axial force $N_{c,f}$ is given by[3]:

$$M_{pr} = 1,25M_{pa} \left(1 - \frac{N_{cf}}{A_{pe}f_{yp,d}} \right) \quad (9)$$

where M_{pa} is the design value of the plastic moment of resistance of the effective cross-section of the profiled steel sheeting

The lever arm z can be taken to be:

$$z = h - 0,5h_c - e_p + (e_p - e) \frac{N_{cf}}{A_{pe}f_{yp,d}} \quad (10)$$

where e_p is the distance from the plastic neutral axis of profiled steel sheeting to the extreme fibre of the composite slab in tension.

Therefore, the design moment resistance of the composite slab in sagging bending is:

$$M_{Rd} = N_{c,f} z + M_{pr} \quad (11)$$

Partial shear connection ($0 < \eta < 1$)

For this case, the compressive force in the slab N_c is given by:

$$N_c = \tau_{u,Rd} b L_x \leq N_{c,f} \quad (12)$$

where $\tau_{u,Rd}$ is the design shear strength ($\tau_{u,Rk} / \gamma_{VS}$) obtained from composite slab tests and L_x is the distance of the cross-section under consideration to the nearest support.

The calculation method for determining the design moment resistance of the composite slab is similar to the case when the neutral axis is within the sheeting and full shear connection exists, except that h_c is replaced with x_{pl} and $N_{c,f}$ is replaced with N_c to give (cf. Equation (10)):

$$z = h - 0,5x_{pl} - e_p + (e_p - e) \frac{N_c}{A_{pe}f_{yp,d}} \quad (13)$$

The reduced bending resistance of the sheeting becomes (cf. Equation (9)):

$$M_{pr} = 1,25M_{pa} \left(1 - \frac{N_c}{A_{pe}f_{yp,d}} \right) \quad (14)$$

And the design moment resistance of the composite slab in sagging bending is given by (cf. Equation (10)):

$$M_{Rd} = N_c z + M_{pr} \quad (15)$$

Supplementary reinforcement

The provision of reinforcing bars within the ribs of the profiled steel sheeting may be taken into account in the partial connection method by simply including an additional stress block in Fig 7 or Fig 8 equal to:

$$N_s = A_s f_{sd} \quad (16)$$

where A_s is the cross-sectional area of the reinforcement and f_{sd} is the design value of the yield strength of reinforcing steel.

End anchorage

Although end anchorage of the type shown in Fig 3(c) and (d) is permitted in EN 1994-1-1, only rules for through-deck welded studs are provided. The design resistance of a headed stud welded through the steel sheet used for end anchorage should be taken as the smaller of the design shear resistance of the stud welded in profiled steel sheeting $P_{Rd} k_t$ (for k_t see Equation (25) and Table 1), or the bearing resistance of the sheet determined from:

$$P_{pb,Rd} = k_\phi d_{do} t f_{yp,d} \quad (17)$$

where d_{do} is the diameter of the weld collar which may be taken as 1,1 times the diameter of the shank of the stud, t is the thickness of the sheeting and:

$$k_\phi = 1 + a / d_{do} \leq 6,0 \quad (18)$$

where a is the distance from the centre of the stud to the end of the sheeting, not to be less than $1,5 d_{do}$.

Equation (17) and (18) have been developed from the bearing failure mechanism shown in Fig 9, where it is assumed that yielding of the sheet occurs in direct tension in front of the stud and in shear, at a stress of $f_{yp,d} / 2$, along the planes indicated.

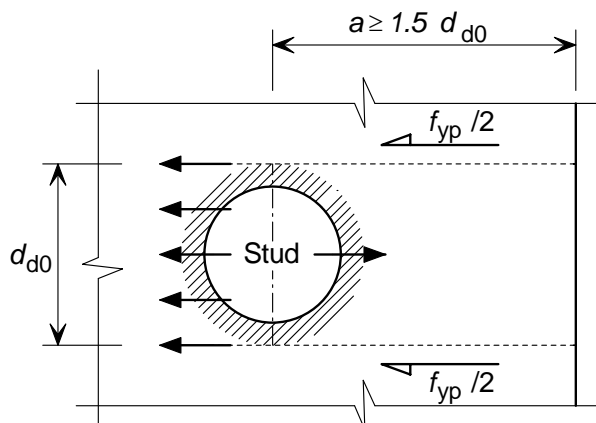

Fig 9. Bearing failure mechanism in profiled steel sheet around stud connector

Should the designer wish to account for end anchorage through the detail given in Fig 3(d) or similar, this contribution should be determined from composite slab tests according to EN 1994-1-1, Annex B.

m-k method without end anchorage

The rules in EN 1994-1-1 are based on the work by Porter and Eckberg in North America[6]. As implied by the name, the *m-k* method is based on establishing the gradient and intercept of a linear relationship evaluated from two groups of composite slab tests; the evaluation of the *m-k* values is shown graphically in Fig 10. For cases when the longitudinal shear behaviour may be considered ductile, V_t is taken as the value of the support reaction at the failure load (i.e. $V_t = F / 2$); however, if the behaviour is brittle, EN 1994-1-1 specifies that the value should be reduced using a factor of 0,8. By plotting the results from the composite slab tests in terms of the vertical shear ($V_t / b d_p$) against shear bond ($A_p / b L_s$), two groups of data are formed corresponding to the long specimens (Group A) and short specimens (Group B). The relationship between vertical shear and shear bond capacity is approximated by constructing a straight line through the two groups of data (see Fig 10). Note that if an overhang with a distance L_0 is provided in the test specimens, unlike the partial shear connection approach, this is ignored in the *m-k* method.

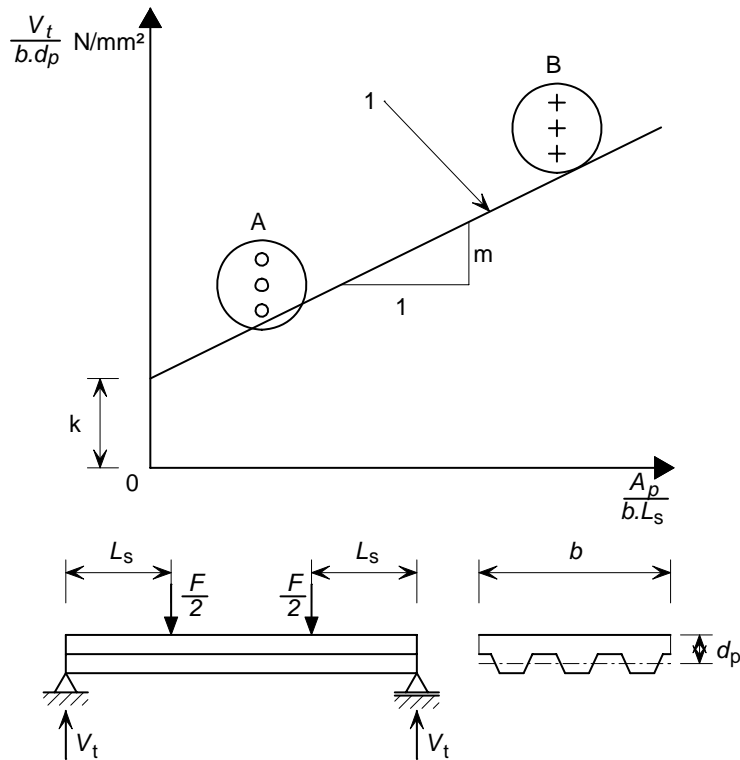

Fig 10. Determination of $m-k$ values from test results

From all the values of V_t , the characteristic shear strength should be calculated from the test values as the 5% fractile and drawn as a characteristic linear regression line to define the characteristic m and k values (Line 1 in Fig 10). If two groups of three tests are used, and the deviation from the mean of any individual test result in a group does not exceed 10%, the characteristic regression line may be determined by one of the following methods:

- According to EN1990, Annex D.
- According to EN1994-1-1 Annex B, taking the minimum value of each group reduced by 10%.

The design value of the resistance to shear for the composite slab using the $m-k$ method is given by:

$$V_{1,Rd} = \frac{bd_p}{\gamma_{VS}} \left(\frac{mA_p}{bL_s} + k \right) \quad (19)$$

where A_p is the nominal cross-section of the sheeting in mm^2

Although the $m-k$ method has been widely used in the design of composite slabs for some time, there are a number of deficiencies in the approach that should be noted by designers[7]:

- (i) The results contain all the influencing parameters, such as materials, slab geometry and composite action; however, it is not possible to separate them from one another.
- (ii) The methodology is not based on a mechanical model and is therefore less flexible than the partial connection method. For example, the benefit of including reinforcement bars, end anchorage, etc. cannot be quantified unless additional tests are undertaken that include these variables.
- (iii) The method of evaluation is the same whether the longitudinal shear behaviour is ductile or brittle. The use of the 0,8 penalty factor for brittle behaviour does not adequately reflect the advantage of using good mechanical interlock, owing to the fact that the advantage increases with span.
- (iv) Other loading arrangements that differ from the test loading can be problematical.

Point (iv) is worthy of some note by designers. From investigations by the present author it has been found that for the case when concentrated loads are applied at a distance from the support $L_p < L_s$, the resistance of the composite slab can be overestimated using the $m-k$ method. It is therefore recommended that when concentrated loads are applied to a composite slab, the $m-k$ method is only used with Equation (21), (22) and (23) when $L_p \geq L_s$.

CONCENTRATED POINT AND LINE LOADS

When concentrated point or line loads are applied parallel to the span of the slab, the loads should be considered to be distributed over a width b_m , measured directly above the ribs of the sheeting, which is taken to be:

$$b_m = b_p + 2(h_c + h_f) \quad (20)$$

where b_p is the width of the load (or taken to the length of the concentrated line load when the load is applied perpendicular to the span of the slab), h_c is the thickness of concrete above the main flat surface of the top of the ribs of the sheeting and h_f is the thickness of finishes, if applied to the slab.

If $h_p / h \leq 0,6$, the effective width of the composite slab b_{em} that may be considered for global analysis and resistance may be determined from the following:

- a) For bending and longitudinal shear:

for simple spans and exterior spans of continuous slabs

$$b_{em} = b_m + 2L_p \left(1 - \frac{L_p}{L} \right) \leq \text{slab width} \quad (21)$$

for interior spans of continuous slabs

$$b_{em} = b_m + 1,33L_p \left(1 - \frac{L_p}{L} \right) \leq \text{slab width} \quad (22)$$

b) For vertical shear:

$$b_{ev} = b_m + L_p \left(1 - \frac{L_p}{L} \right) \leq \text{slab width} \quad (23)$$

where L_p is the distance from the centre of the load to the nearest support and L is the span length.

If the characteristic imposed loads do not exceed the values given below, a nominal transverse reinforcement of not less than 0,2% of the area of concrete above the ribs of the sheet (which extends over a minimum anchorage length beyond b_{em}), may be provided without any further calculation; see Fig 11.

- concentrated load = 7,5 kN;
- distributed load = 5,0 kN/m².

For characteristic imposed loads greater than these values, the distribution of bending moments and the appropriate amount of transverse reinforcement should be evaluated according to EN 1992-1-1.

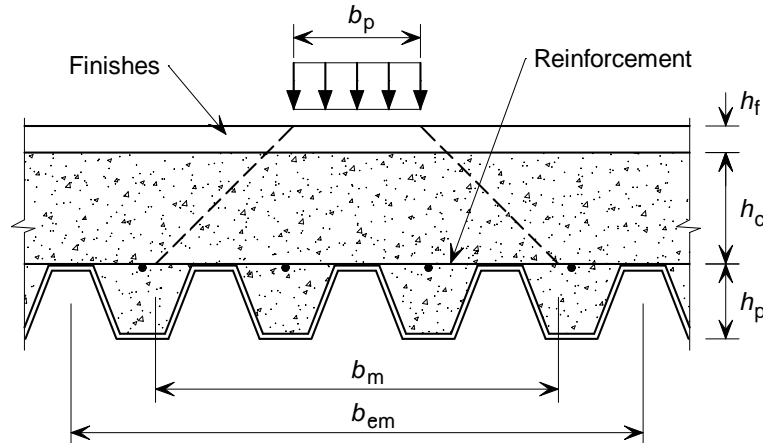

Fig 11. Distribution from a concentrated load

VERTICAL SHEAR

The vertical shear resistance of a composite slab $V_{v,Rd}$ should be determined using EN 1992-1-1, which depends on the effective depth of the cross-section to the centroid of the tensile reinforcement. In the ENV version of EN 1994-1-1 it was permitted to take the sheeting as the tensile reinforcement provided that it was fully anchored beyond the section considered. For heavily loaded slabs, additional reinforcement may be required at the support when the profiled steel sheeting is discontinuous and only has limited anchorage.

PUNCHING SHEAR

For cases when point loads are applied to a composite slab, for example, from the wheels of a mobile elevating work platform (MEWP), the punching shear resistance $V_{p,Rd}$ should be assessed. Failure is assumed to occur on a critical perimeter shown in Fig 12.

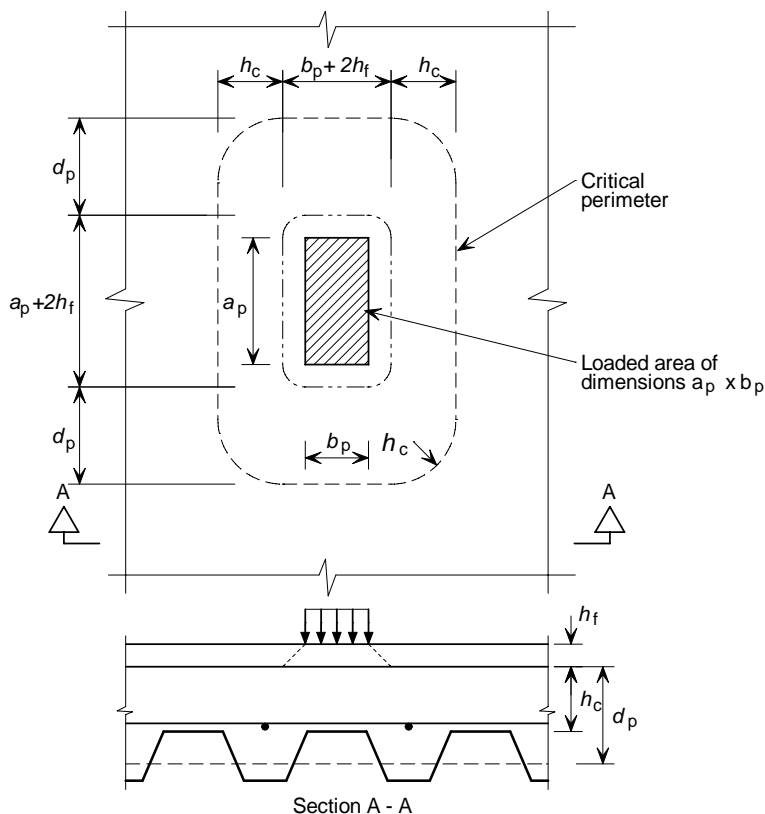

Fig 12. Critical perimeter for punching shear

The punching shear resistance $V_{p,Rd}$ should be calculated according to EN 1992-1-1, using the critical perimeter in Fig 12. For a loaded area $a_p \times b_p$ that is remote from a free edge, which is applied to a screed with a thickness h_f , the critical perimeter is given by[8]:

$$c_p = 2 \pi h_c + 2 (b_p + 2 h_f) + 2 (a_p + 2 h_f + 2 d_p - 2 h_c) \quad (24)$$

VERIFICATION OF COMPOSITE SLABS FOR SERVICEABILITY LIMIT STATES

CRACK WIDTHS

Cracking to the surface of the concrete slab will occur when the slab is continuous over a supporting beam. As a consequence of this, longitudinal reinforcement should be provided over the supports. According to EN 1994-1-1, when continuous slabs are

designed as simply-supported, the minimum cross-sectional area of the anti-crack reinforcement within the depth h_c should be as follows:

- 0,2% of the cross-sectional area of the concrete above the ribs for unpropped construction
- 0,4% of the cross-sectional area of the concrete above the ribs for propped construction.

The above amounts do not automatically ensure that the crack widths are less than the recommended value of $w_{\max} = 0,3$ mm given in EN1992-1-1 for certain exposure classes. If the exposure class is such that cracking needs to be controlled, the slab should be designed as continuous, and the crack widths in hogging moment regions evaluated according to EN 1992-1-1.

DEFLECTION

In addition to the deflection of the sheeting at the construction stage (if unpropped), the deflection of the composite slab should also be considered. Deflections due to loading applied to the composite member should be calculated using elastic analysis, neglecting the effects of shrinkage. However, EN 1994-1-1 permits calculations of the deflection of the composite slab to be omitted if both the following conditions are satisfied for external or simply-supported spans:

- the span/depth ratio of the slab does not exceed the limits given in EN 1992-1-1 for lightly stressed concrete (these are 20 for a simply-supported span and 26 for an external span of a continuous slab); and
- the load causing an end slip of 0,5 mm in the tests on composite slabs exceeds 1,2 times the design service load.

For cases where the end slip exceeds 0,5 mm at a load below 1,2 times the design service load, two options exist to the designer:

- (i) end anchors should be provided; or
- (ii) deflections should be calculated including the effect of end slip.

Should the behaviour of the shear connection between the sheet and the concrete not be known from tests on composite slabs with end anchorage, EN 1994-1-1 permits a tied-arch model to be used. Guidance for designers on this case can be found in reference[5].

For an internal span of a continuous slab, which possess shear connection as defined in Fig 3(a), (b) and (c), the deflection may be determined using the following:

- the average value of the cracked and uncracked second moment of area may be taken.

- the average value of the modular ratio for long-term and short-term effects may be used.

DESIGN RESISTANCE OF HEADED STUDS USED WITH PROFILED STEEL SHEETING IN BUILDINGS

Historically, the performance of shear connectors has been established from small-scale specimens of the type shown in Fig 13(a). By applying a load to the top end of the steel-section, the load-slip behaviour of the connectors can be determined. This type of specimen is known as a ‘push test specimen’ in EN 1994-1-1 and, apart from slight geometrical variations, has hardly changed since its inception in the 1930’s[9].

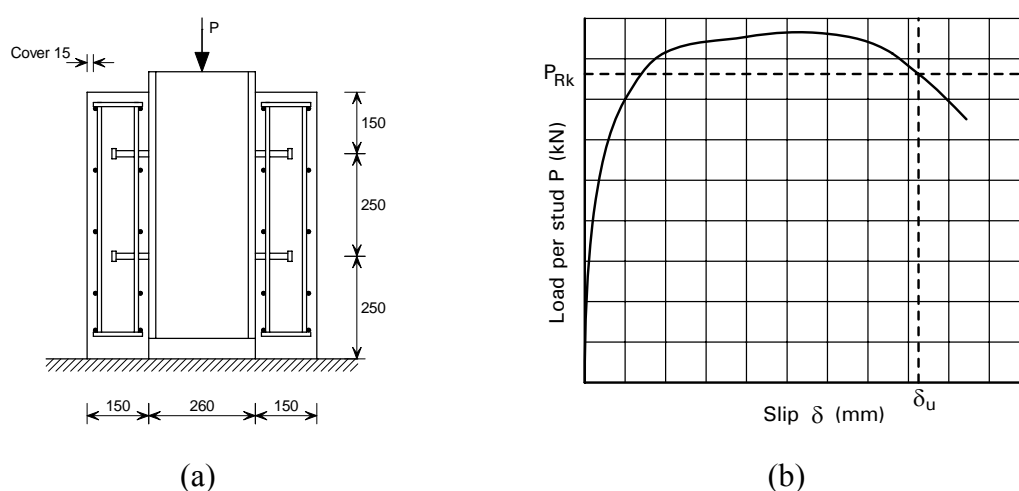

Fig 13. (a) Standard push test specimen according to EN 1994-1-1 (b) Determination of characteristic resistance and slip capacity from push test load-slip curve

According to EN 1994-1-1, if 3 nominally identical tests are carried out and the deviation from the mean value obtained from all the tests does not exceed 10%, the characteristic resistance of a shear connector P_{Rk} is defined as 0.9 times the minimum failure load per stud (see Fig 13 (b)). The ductility of a shear connector is measured by the slip capacity δ_u , which is defined as the slip at the point where the characteristic resistance of the connector intersects the falling branch of the load-slip curve (see Fig 13 (b)). The characteristic slip capacity δ_{uk} is taken as 0.9 times the minimum test value of δ_u . Alternatively, the characteristic properties of the shear connector can be determined by a statistical evaluation of all of the results according to EN 1990. In Eurocode 4, a connector may be taken as ductile if the characteristic slip capacity δ_{uk} is at least 6 mm.

When stud connectors are welded within the ribs of profiled steel sheeting, which is orientated perpendicular to the longitudinal axis of the supporting beams (known as secondary beam locations), their resistance is reduced when compared to studs embedded in solid concrete slabs. To account for this reduced resistance, reduction factor formulae have been derived from push tests. The reduction factor formula given by EN 1994-1-1, which should be multiplied by the design resistance of a stud embedded in a solid concrete slab P_{Rd} , is as follows:

$$k_t = 0.85 / \sqrt{n_r} (b_0 / h_p) \{ (h_{sc} / h_p) - 1 \} \leq k_{t,max} \quad (25)$$

where n_r is the number of stud connectors in one rib at the beam intersection, not to exceed two in calculation of the reduction factor k_t and of the longitudinal shear resistance of the connection, b_0 is the average breadth of the concrete rib for open web profiles (or the minimum breadth of the concrete rib for re-entrant profiles), h_p is the overall depth of the profiled steel sheeting excluding embossments, h_{sc} is the height of the stud and the upper limits to $k_{t,max}$ are given in Table 1.

Table 1 Upper limits $k_{t,max}$ for the reduction factor k_t

Number of stud connectors per rib	Thickness t of sheet (mm)	Studs not exceeding 20 mm in diameter and welded through profiled steel sheeting	Profiled steel sheeting with holes and studs 19 mm or 22 mm in diameter
$n_r = 1$	$\leq 1,0$	0,85	0,75
	$> 1,0$	1,00	0,75
$n_r = 2$	$\leq 1,0$	0,70	0,60
	$> 1,0$	0,80	0,60

As shown in Fig 1, for open trough profiles, there is sometimes a central stiffener within the rib so that it is usually not possible to weld the stud to the beam in the centre of the trough; in these circumstances the studs must be offset. This eccentric positioning places the connector in the so-called 'favourable' or 'unfavourable' position (see Fig 14).

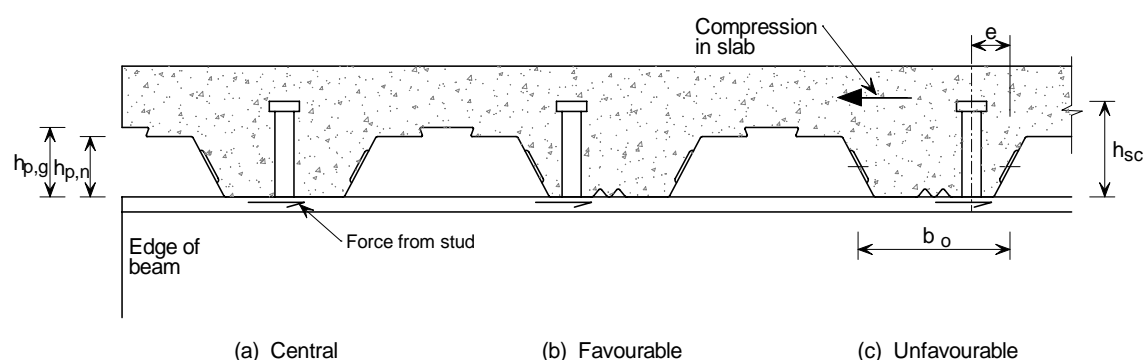

Fig 14. Dimensions of profiled steel sheeting and studs in the (a) central (b) favourable (c) unfavourable position

As implied by the name, favourable studs result in greater resistances than centrally welded studs; conversely, unfavourable studs result in weaker resistances. Also, it has been shown from recent research on full-scale beam tests with open trough profiles[10] that this positioning also affects the ductility of the stud connectors in a similar way.

According to EN 1994-1-1, for these situations the studs should be welded alternately on the two sides of the trough throughout the length of the span. It is assumed that this detailing measure will cause the favourable and unfavourable effects to balance out, and provide a resistance equivalent to that which would have been achieved had it been possible to weld the stud in the central position (this approach has been recently verified through full-scale beam tests in the UK[10]).

For cases when the resistance of shear connectors welded in open trough profiles needs to be established from tests, it has been found that the results have sometimes been adversely affected by an artificial mode of failure caused by the rotation of the last studded rib at the top of the specimen[11]; this has sometimes been described as a ‘back-breaking’ failure. To eliminate this artificial failure mode, it has been recommended that the standard specimen should be detailed according to Fig 15 when open trough sheeting is used.

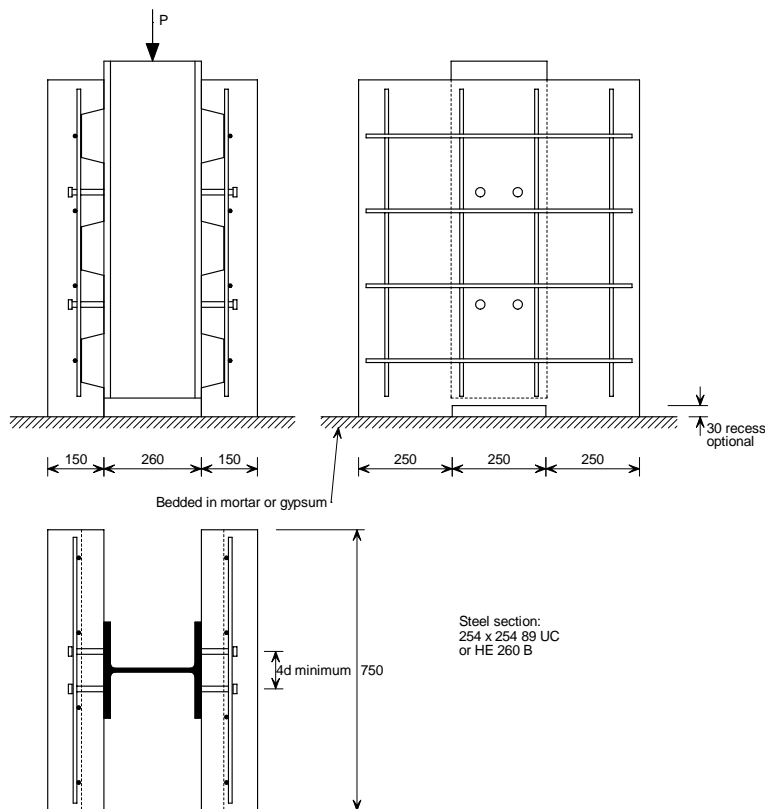

Fig 15. Recommended detailing to the standard specimen when shear connectors are used with open trough profiled steel sheeting.

REFERENCES

1. Hicks, S.J., Lawson, R.M., Rackham, J.W. and Fordham, P. Comparative Structure Cost of Modern Commercial Buildings (Second Edition), SCI Publication 137, The Steel Construction Institute, Ascot, p 85, 2004.
2. Bryan, E.R. & Leach, P.: 'Design of profiled sheeting as permanent formwork', Construction Industry Research and Information Association, London, Technical Note 116, 1984.
3. Stark, J.W.B. & Brekelmans, J.W.P.M.: 'Plastic design of continuous composite slabs', Journal of Constructional Steel Research, 15, 1990, pp. 23-47.
4. Newman, G.M.: 'The fire resistance of composite floors with steel decking (Second Edition), SCI Publication 056, The Steel Construction Institute, Ascot, p 29, 1991.
5. Johnson, R.P. & Anderson, D.: Designers' Guide to EN 1994-1-1: Eurocode 4: Design of Composite Steel and Concrete Structures, Part 1-1: General Rules and Rules for Buildings, Thomas Telford, 2004.
6. Porter, M.L. & Eckberg, C.E.: 'Design recommendations for steel deck floor slabs', ASCE, Journal of the Structural Division, 102, No. 11, 1976, pp. 2121-2136.
7. Bode, H. & Sauerborn, I.: 'Modern design concept for composite slabs with ductile behaviour', In: Easterling, W.S. & Roddis, W.M.K. (eds), Composite Construction in Steel and Concrete II, American Society of Civil Engineers, New York, 1993, pp. 125-141.
8. Johnson, R.P.: Composite Structures of Steel and Concrete: Beams, Slabs, Columns and Frames for Buildings (Third Edition), Blackwell Publishing, 2004.
9. Roš, M. 'Les constructions acier-beton system Alpha', L'Ossature Métallique, 3/4, 1934, pp.195-208.
10. Hicks, S.J.: Strength and ductility of headed stud connectors welded in modern profiled steel sheeting, The Structural Engineer, 85, No. 10, 2007, pp 32-38.
11. Johnson, R.P.: 'Shear connection in beams that support composite slabs – BS5950 and EN 1994-1-1', The Structural Engineer, 83, No.22, 2005, p 21-24.